

# Motorized Pantograph

## SPECIFICATIONS

Identity No.	R006MSL
Max. Working Load	60 kg
Extended Length	6 m
Closed Length	1.6 m
Lifting Rope	Ø3 mm Steel wire x2
Top Mounting	Ø28mm Spigot Motorized Trolley
Bottom Mounting	Ø28mm Socket
Motor Capacity	0.37kW 220/380V AC
Travel Speed	7 m/min.
Gear Box	r = 80:1
Lighting Circuit	16A (3 x 2.5 mm <sup>2</sup> ) / CEE 17 (on request)
DMX	XLR-5
Self Weight	59 kg



## DIMENSIONS (mm)

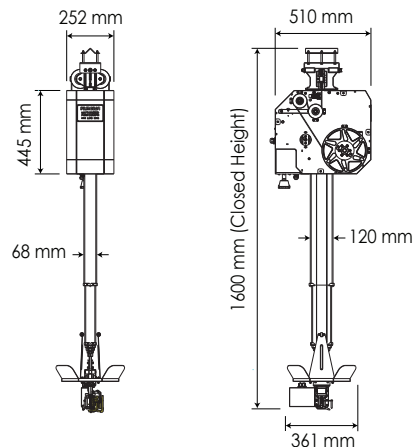

## PRODUCT FEATURES

The Motorized Monopole is designed for TV Studio with working height up to 6 meters to control the vertical position of lights, speakers and other gear.

## SAFETY & STANDARD FEATURES

- Slack Cable Protection
- Overload Protection
- Top & Bottom Travel limit
- Local or P.O. Up/Down Operation

## OPTIONAL FEATURES

- Auxiliary Circuit - Ethernet, Audio, Video, etc.

## MOTORIZED TROLLEY

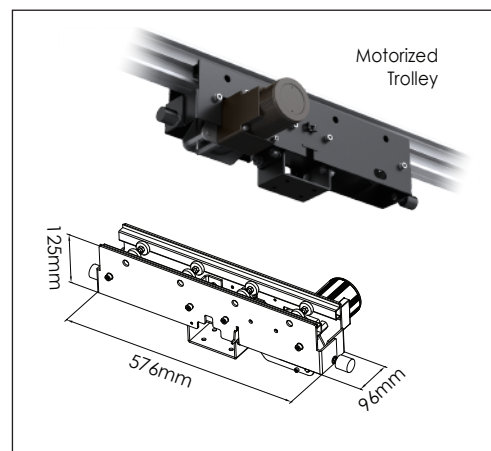

Motorized Trolley can be hung on & Travelled with Top Rail